

Fluid-o-Tech magnet drive gear pumps MGC4-MGC11 DC pump/motor units



The “MG200” Series magnet drive gear pumps are compact precision performance pumps for high technology applications.

The magnet drive principle provides a totally sealed pump chamber which

is capable of handling a wide range of corrosive liquids with a high degree of safety. The pump housing is available in AISI 316L, SAF 2205 or AISI 303. The Gears are available in PTFE or Peek™.

In operation the MG200 Series pumps are noiseless, pulsation-free and capable of handling relatively high temperature liquids i.e. 120 °C (248 °F) with a low coefficient of expansion.

The principle of the magnetic drive comprises an inner magnet embodied in the pump and connected to the driving gear, and an outer magnet connected to the motor shaft. The pole-to-pole alignment of the two magnets provides the driving motion to the pump. Decoupling will occur when the pump load exceeds the coupling torque between the magnets.

- 1/8" NPT or GAS ports
- Relief valve available upon request

MGC4-MGC11

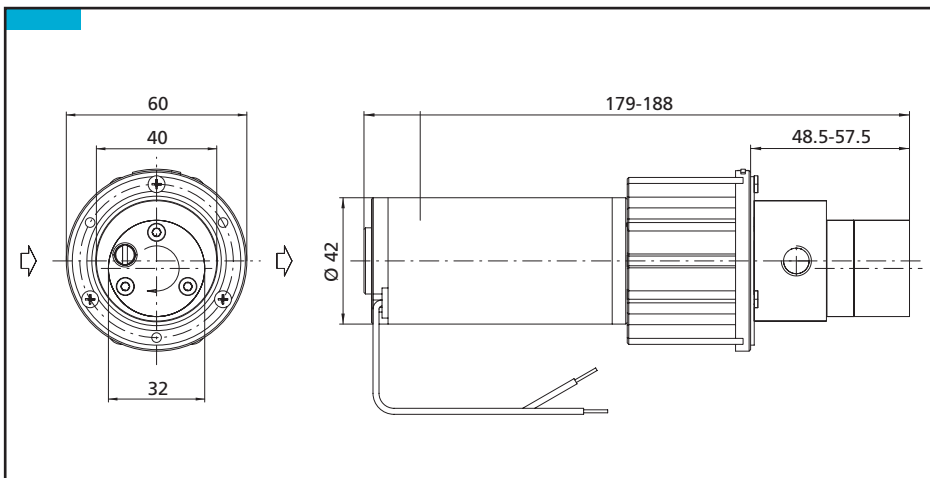

Main Applications

- Medical and surgical equipment
- Hemodialysis apparatus
- Seal flush
- Laser apparatus
- Lubrication
- “Ink-jet” printing systems
- Cooling systems
- Laboratory instrumentation
- Water purification and ultra-filtration
- Sampling
- Food processing equipment

Fluid-o-Tech magnet drive gear pumps MGC4-MGC11 DC pump/motor units

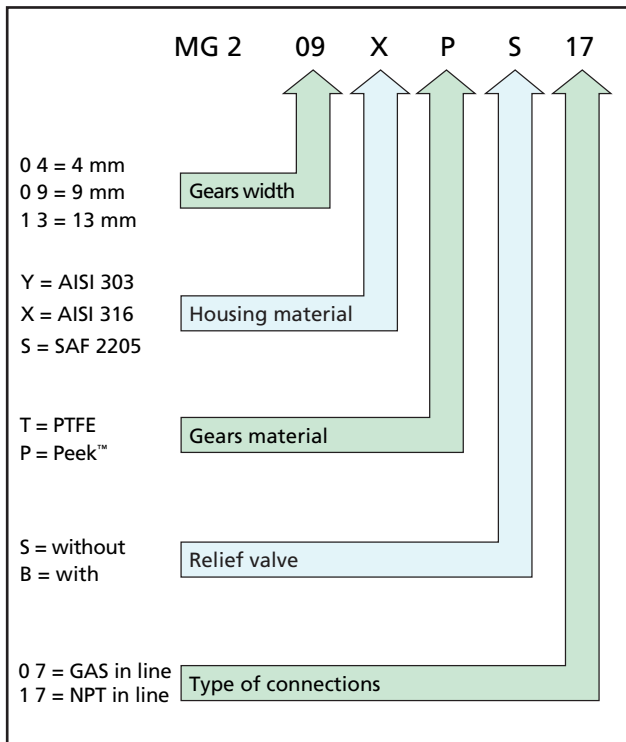

Composition materials			Technical informations	
Housing	Gear	Seal	Temperature range	Max system pressure
AISI 316	PTFE	PTFE	-45 to 50 °C / -49 to 122 °F	20 bar / 290 psi
AISI 316	peek™	PTFE	-45 to 120 °C / -49 to 248 °F	20 bar / 290 psi

Drive type	MGC4	MGC11
Voltage (V)	12 DC	24 DC
Rated speed (rpm)	3.300	3.000
Current consumption (A)	3,4	1,5
Output power (W)	25,9	23,6
Weight (g)	500	500

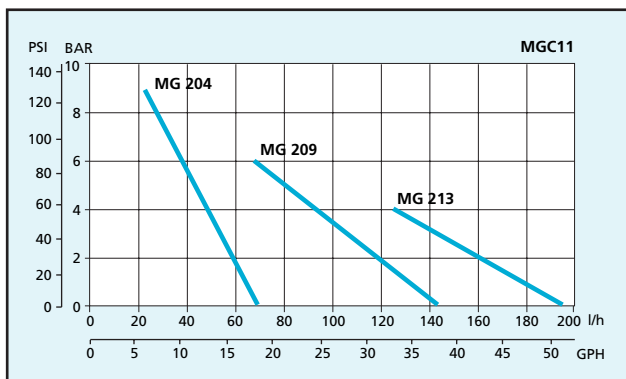
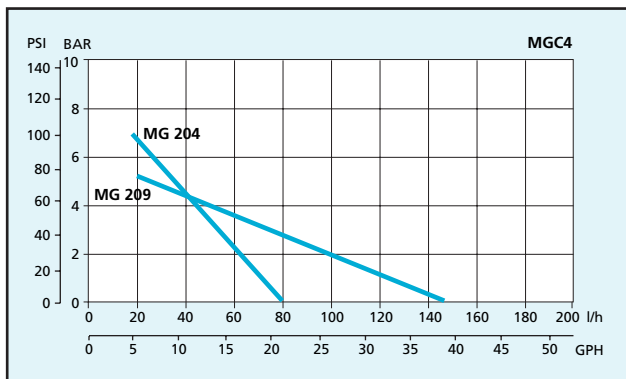
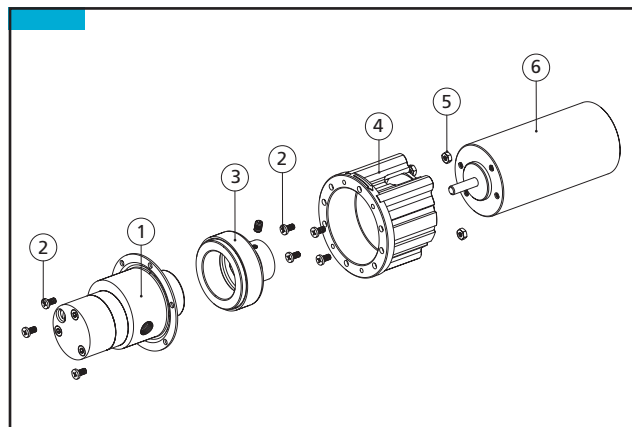

Pos.	Description	Features	Code
1	Pump	-	-
2	Screws	M3 X 6 AISI 304	6210030
3	Driving magnet	5 MM BORE	1250000
4	Adapter	PLASTIC	6230660
5	Bolts	-	6212080
6	Motor MGC4	12 V DC 25,9 W	6920020
	Motor MGC11	24 V DC 23,6 W	6920021

Notes: Characteristics with water at 20 °C and without by-pass, max vacuum mm Hg 724
Use filter before pump inlet not larger than 20 microns
Temperature requirements different from ambient temperature must be mentioned on the order
SPECIFY PUMP MODEL WHEN ORDERING THE UNIT

Fluid-o-Tech reserves the right to alter the specifications indicated in this catalogue at any time and without prior notice

MGC4-11 – 09/04 Ed.



Fluid-o-Tech
PUMP TECHNOLOGY AT ITS BEST

Via Morimondo, 23
20143 Milano - Italy
Tel. (39) (02) 8917071
Fax (39) (02) 89170799

161 Atwater St.,
Plantsville CT (USA) 06479
Tel. (1) (860) 276-9270
Fax (1) (860) 620-0193

203, 2-17-19, Ebara, Shinagawa
Tokyo 142-0063, Japan
Tel. (81) (0) 3-3783-9660
Fax (81) (0) 3-3783-9661